

200W X-Band BUC/ SSPB/ SSPA

Second Generation GaN Technology

SSPBM-X 2200-G series

Features

- Output power of 200W in a single compact package
- High linearity
- Full M&C capability via RS485 or Ethernet port (optional)
- Weatherproof construction
- CE marking
- MIL-STD-188-164A latest revision compliant



Overview

Based on Second Generation GaN technology the new G-Series X-Band BUCs provide high power density in a compact size. Combined with the traditional features from Advantech Wireless Technologies, these new series of BUCs provide the ultimate in performance and convenience.

The products in the new G-Series X-Band BUCs are available as SSPA or SSPB (BUC).

Options

- Ethernet port
- 70 dB Receive Reject Filter (external)
- Harmonic filter (external)

Accessories

- Mounting kits
- External Receive Reject Filter
- External Transmit Reject Filter (for RX path)
- Remote M&C panel with optional SNMP
- Flexible and rigid waveguides
- Mounting frames
- High power terminations
- Replacement fans

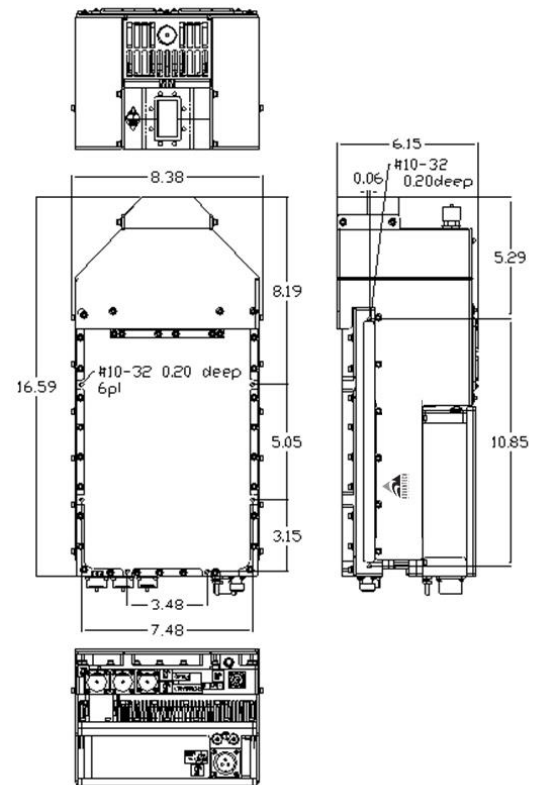



200W X-Band BUC/ SSPB/ SSPA Second Generation GaN Technology

Technical Specifications	
	200W
Operating Frequency	7.9 – 8.4 GHz
L-Band input (BUC/SSPB)	950 – 1450 MHz
Output Power	P _{SAT} +53.0 dBm min P _{LINEAR} +49.0 dBm
Gain	74dB ± 3 dB
Gain adjustment range	20 dB in 0.1 dB steps
Gain flatness over full band	4 dB p-p max
Gain slope over 40 MHz	1dB p-p dB max
Gain variation over temperature	± 1.5 dB max
Input Impedance and VSWR	50 Ω 1.3:1
Output VSWR	1.25:1 with optional Output Isolator
Noise power density	-75 dBm/Hz in Transmit Band, -110 dBm/Hz in Receive Band (7.25 – 7.75 GHz) -145 dBm/Hz with optional external Receive Reject Filter
Spurious	-55 dBc max at P _{LINEAR}
Harmonics	-40 dBc @ P _{LINEAR}
AM/PM conversion	1°/dB at P _{LINEAR}
Third order intermod (two tones)	-25 dBc two signal 5 MHz apart at P _{LINEAR}
Spectral regrowth	30 dBc @ P _{LINEAR}
Group delay	Ripple 1 nsec p-p max
Local Oscillator freq.	6.95 GHz
Phase Noise	-53 dBc/Hz at 10Hz -83 dBc/Hz at 10 kHz -63 dBc/Hz at 100Hz -95 dBc/Hz at 100 kHz -73 dBc/Hz at 1000Hz
External Reference Frequency phase noise (max)	10 MHz -120 dBc/Hz at 10Hz -155 dBc/Hz at 10 kHz -135 dBc/Hz at 100Hz -160 dBc/Hz at 100 kHz -150 dBc/Hz at 1000Hz
Dimensions	16.6" x 8.5" x 5.5" (406 x 200 x 140 mm)
Weight	30 lbs. (13.6 kg)
Input voltage	DC 48V (40v – 60V) AC 90 – 265 VAC (47 – 63 Hz)
Power consumption (nominal)	1100W at Psat, 900W at P _{LINEAR}
Interfaces	Input (L-Band) N type female RF output CPR112 DC line MS3102 type AC line MS3102 type RS485/Ethernet MS3112 type
Environmental	Temperature Operating -30°C to +55 °C Option 1 -40°C to +55 °C Storage -55°C to +85 °C Humidity 100% condensing Altitude 10,000' AMSL, de-rated by 2 °C/1000' from AMSL

Ref.: PB-SSPBMg-2G-X-200W-19109

NORTH AMERICA

USA
info.usa@advantechwireless.com

CANADA
Info.canada@advantechwireless.com

EUROPE

UNITED KINGDOM
info.uk@advantechwireless.com

RUSSIA & CIS
info.russia@advantechwireless.com

SOUTH AMERICA

info.latam@advantechwireless.com

BRAZIL
info.brazil@advantechwireless.com

ASIA

info.asia@advantechwireless.com

INDIA
info.india@advantechwireless.com